

# SKETCH/AREA TABLE ADDENDUM

Parcel No 0026-009.000

SUBJECT	Property Address
City	State
Owner	Zip
Client	
Appraiser Name	

IMPROVEMENTS SKETCH

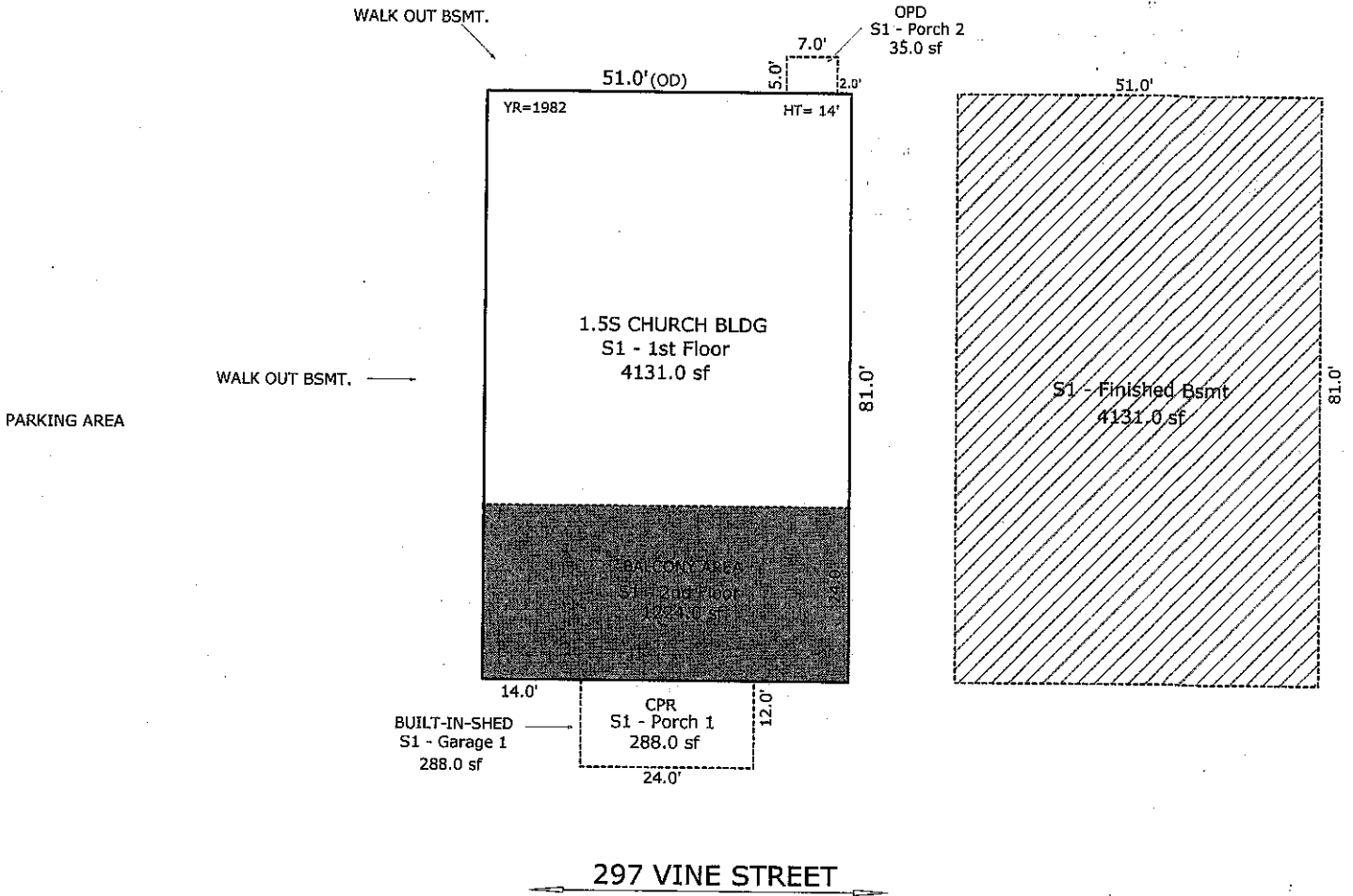

Scale: 1 = 25

### AREA CALCULATIONS SUMMARY

Code	Description	Factor	Net Size	Perimeter	Net Totals
1FL1	S1 - 1st Floor	1.00	4131.0	264.0	4131.0
1FL2	S1 - 2nd Floor	1.00	1224.0	150.0	1224.0
1BS	S1 - Basement	1.00	4131.0	264.0	4131.0
1BF	S1 - Finished Bsmt	1.00	4131.0	264.0	4131.0
GAR11	S1 - Garage 1	1.00	288.0	72.0	288.0
P/P11	S1 - Porch 1	1.00	288.0	72.0	288.0
P/P12	S1 - Porch 2	1.00	35.0	24.0	35.0
<b>Net BUILDING Area (rounded w/ factors)</b>					<b>5355</b>

Comment Table 1	
Comment Table 2	Comment Table 3

AREA CALCULATIONS

# SKETCH/AREA TABLE ADDENDUM

Parcel No 0026-009.000

Property Address

City State Zip

Owner

Client

Appraiser Name

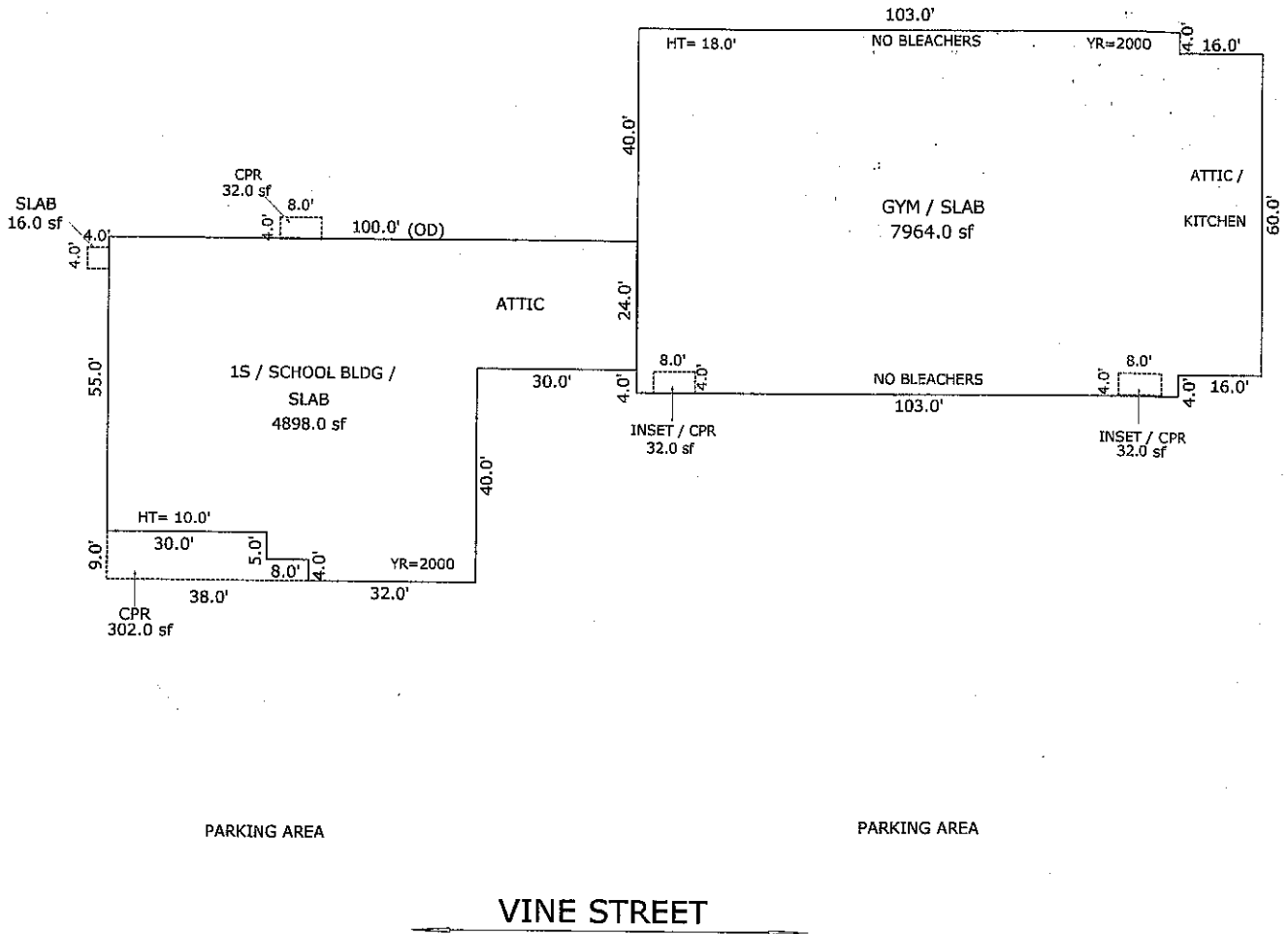

AREA CALCULATIONS SUMMARY					
Code	Description	Factor	Net Size	Perimeter	Net Totals
OTH	1S / SCHOOL BLDG /	1.00	4898.0	328.0	
	GYM / SLAB	1.00	7964.0	374.0	12862.0

Comment Table 1	
Comment Table 2	Comment Table 3

AREA CALCULATIONS

IMPROVEMENTS SKETCH

SUBJECT

# SKETCH/AREA TABLE ADDENDUM

Parcel No 0026-009.000

Property Address

City

State

Zip

Owner

Client

Appraiser Name

SUBJECT

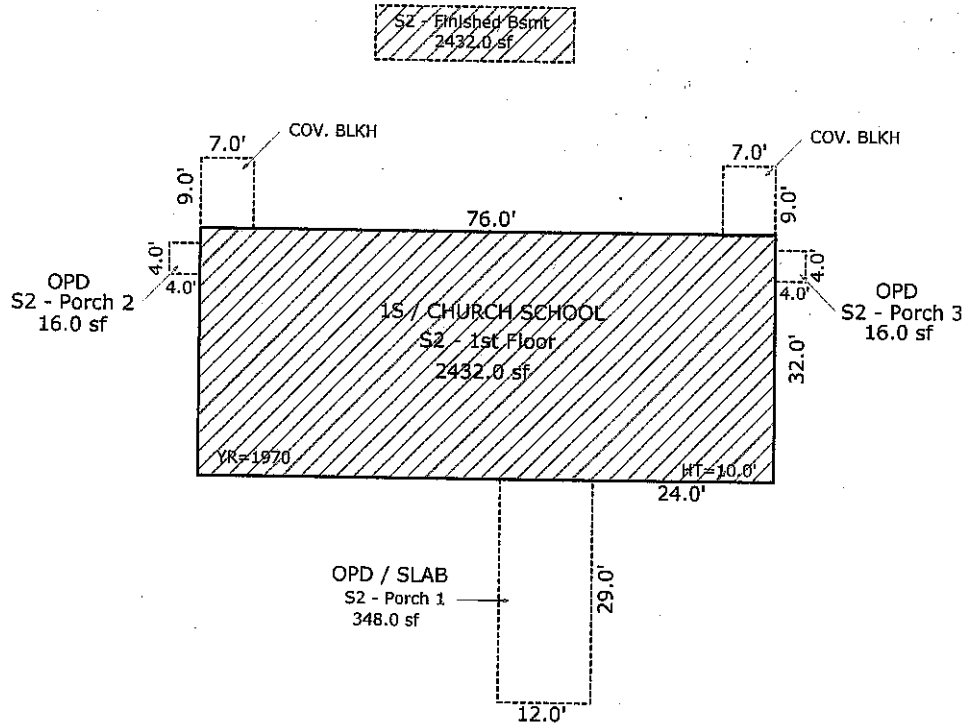

317 VINE STREET

Scale: 1 = 25

## AREA CALCULATIONS SUMMARY

Code	Description	Factor	Net Size	Perimeter	Net Totals
2FL1	S2 - 1st Floor	1.00	2432.0	216.0	2432.0
2BS	S2 - Basement	1.00	2432.0	216.0	2432.0
2BF	S2 - Finished Bsmt	1.00	2432.0	216.0	2432.0
P/P21	S2 - Porch 1	1.00	348.0	82.0	348.0
P/P22	S2 - Porch 2	1.00	16.0	16.0	16.0
P/P23	S2 - Porch 3	1.00	16.0	16.0	16.0

## Comment Table 1

## Comment Table 2

## Comment Table 3

Net BUILDING Area (rounded w/ factors) 2432

AREA CALCULATIONS